

Xtek



**Xtek Wheels:
Operating Safely in
the Most Demanding
Applications**

Xtek Wheel Products



In 1909, our company was formed by solving tough problems with the development of the steel hardening method, eventually known as the Tool Steel Process (TSP). Since 1909, Xtek Inc. has continued to hone and apply our design, metallurgical, and heat-treatment techniques to solve customers' problems.

Today, our worldwide customer base operates heavy duty applications within the toughest, most demanding environments found in industry. These customers choose Xtek wheel products and realize the benefits from our century long commitment to providing safe and reliable wheel products.

We invite you to consider us for your next project.

Engineering

- Highly engineered and customized products.
- Engineering team involved from concept and design, through manufacturing, to evaluation and the eventual servicing and reconditioning of used components.
- This cycle of improvement, ensures each heavy duty, industrial wheel is optimized for peak performance.

Manufacturing

- Wheels are machined to precise tolerances and stringent specifications on state-of-the-art machine tools.
- Facilities and factories focused solely on wheel manufacturing.
- Highly capable of machining component parts to complete application ready assemblies.

Dedicated to Continuous Improvement.

X Wheel gets new designs to manufacturing quicker.

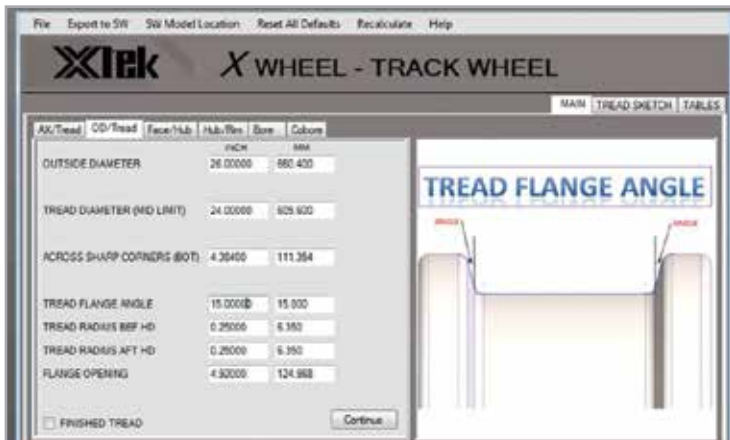

Dedicated to Continuous Investment.

High-precision machines enhance our capabilities.

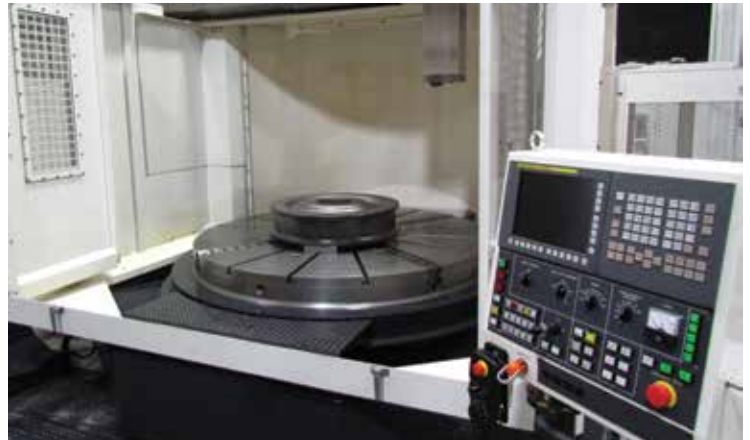



Xtek Wheels: Producing More Turns than the Competition!

- Designed to meet or exceed original equipment manufacturer specifications
- Engineered for optimal performance and integrity
- Manufactured to ISO 9001 quality standards
- Metallurgically tailored to optimize material properties
- Heat-Treated using the Xtek Tool Steel Processes (TSP)

Metallurgy & Thermal Processing

- Xtek metallurgists select the best material and heat treatment from a vast range of options.
- Precise, repeatable metallurgical processes result in optimum product life, superior safety and with minimal maintenance.
- Over 100 years and counting: Xtek's TSP processes customize the properties of wheel components, resulting in metallurgically superior products.



Crane and Track Wheels

Xtek's TSP crane and track wheel assemblies have received a superior safety record throughout all heavy duty, industrial applications.

Xtek's Experience and Processes Pay Dividends

Our engineers and metallurgists have refined the TSP contour hardening process, which is proven to provide the safest, most dependable wheel on the market. Additional benefits include reduced maintenance, improved rail life and significantly higher load carrying capability.

Did You Know?

Over 40% of all crane wheel assembly replacements are due to excessive flange wear and breakage.

Xtek Has the Solution...

Hardened Surface with a Ductile Flange

Xtek's forged steel, coupled with our TSP contour hardening process produces ductile core properties backing up the 58-62 HRC hardened flange surface profile.

This process results in the following benefits:

- Wear resistant wheel tread and flange for longer, safer life
- Absorbs shock loads, vital for wheel flange toughness
- Assists in prevention of spalling and pitting
- Higher load capability results from heat-treatment placing wheel tread and flanges into compression

Finite Element Analysis (FEA) showing typical stress profile of wheel and rail.

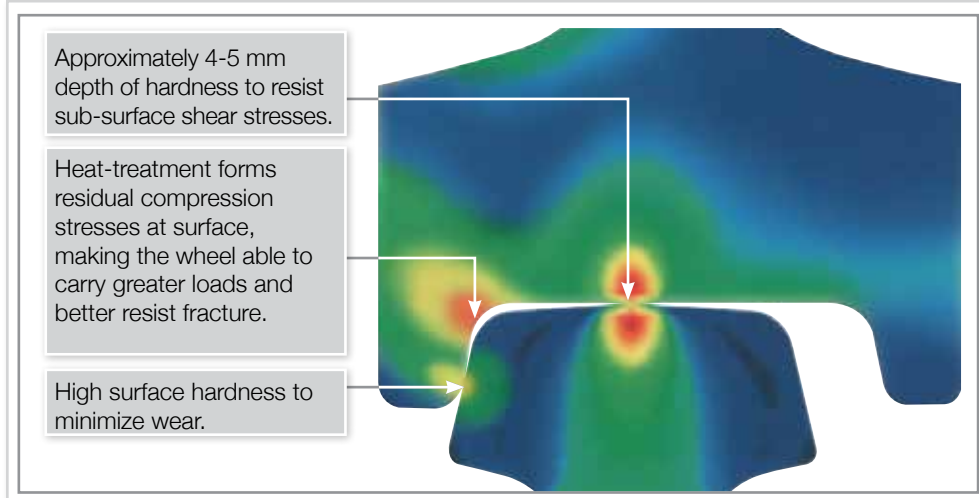

Superior Track Record Operating On:

- Overhead cranes and industrial rail
- Circular tracks (antennae, tower cranes, ladle turrets)
- Port, wood yard & gantry cranes
- The world's largest derrick crane

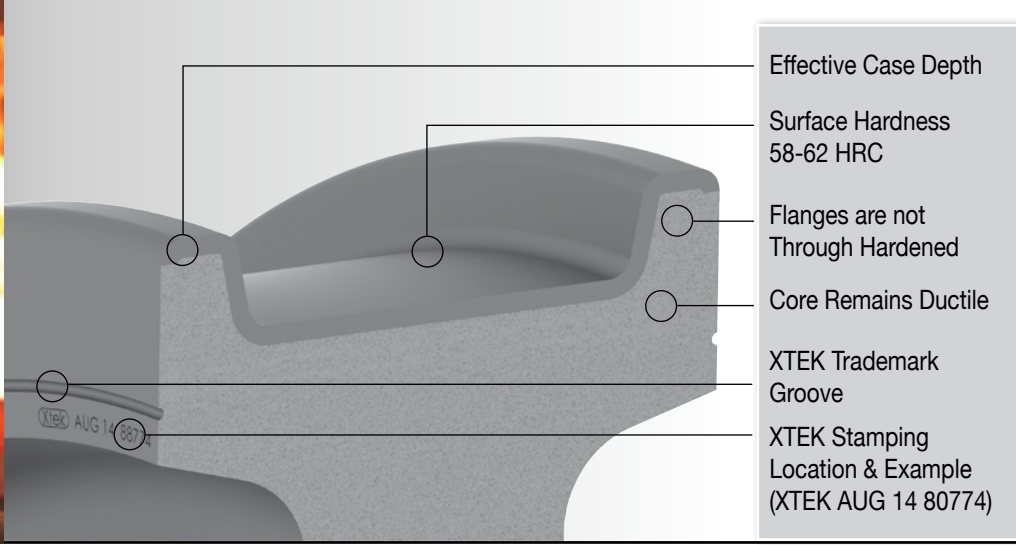

Xtek wheels work harder to improve your rail life!

Xtek's TSP contour hardening process produces ductile core properties backing up the 58-62 HRc hardened flange surface profile.



Other wheel hardening techniques can catastrophically fail under misalignment or impact loads



Wear depth test results - 10,000 cycles

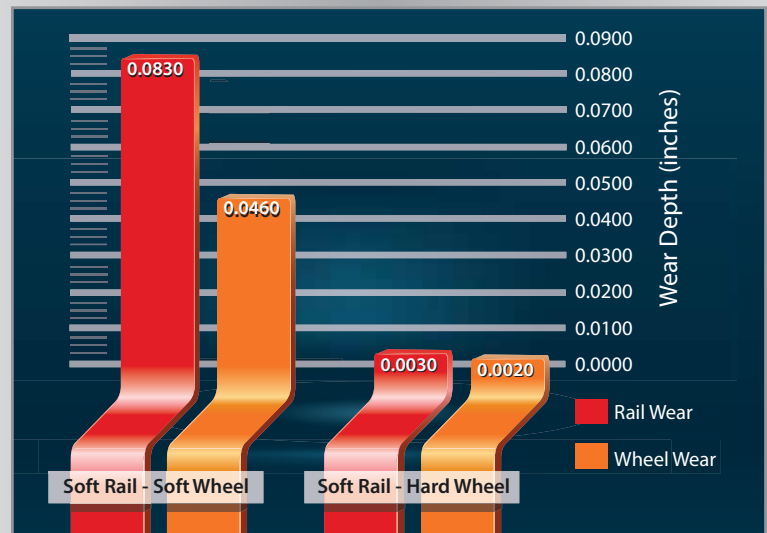

Xtek's 58-62 HRc wheels reduce wear of both the wheel and the soft rail.

Results from an independent research laboratory.



CAUTION

Other hardening techniques produce inconsistent hardness profiles and brittle flanges, which can be catastrophic.

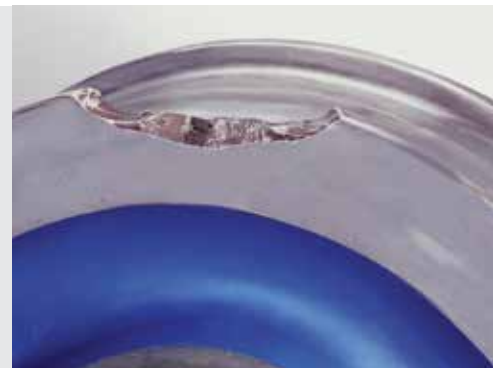

Tyres and Rollers

Xtek's TSP tyres and guide rollers are selected throughout the world for their superior durability and reliability.

Xtek's the Right Choice, Our Solutions Are Proven!

Similar to our crane and track wheels, Xtek tyres and guide rollers are forged from steel and feature Xtek's TSP contour hardening process. This results in ductile core properties backing up the 58-62 HRc hardened surface profile.

Xtek Will

- Evaluate and improve your existing configuration of material, design, and heat-treatment
- Supply a new wheel
- Mount the wheel
- Offer a complete drop in solution to include bearings, bearing housings, coupling and gear

Performance Advantage

- Increased wear life of the wheel tread
- Increased wear life of the existing rail
- Improved vertical load carrying capability

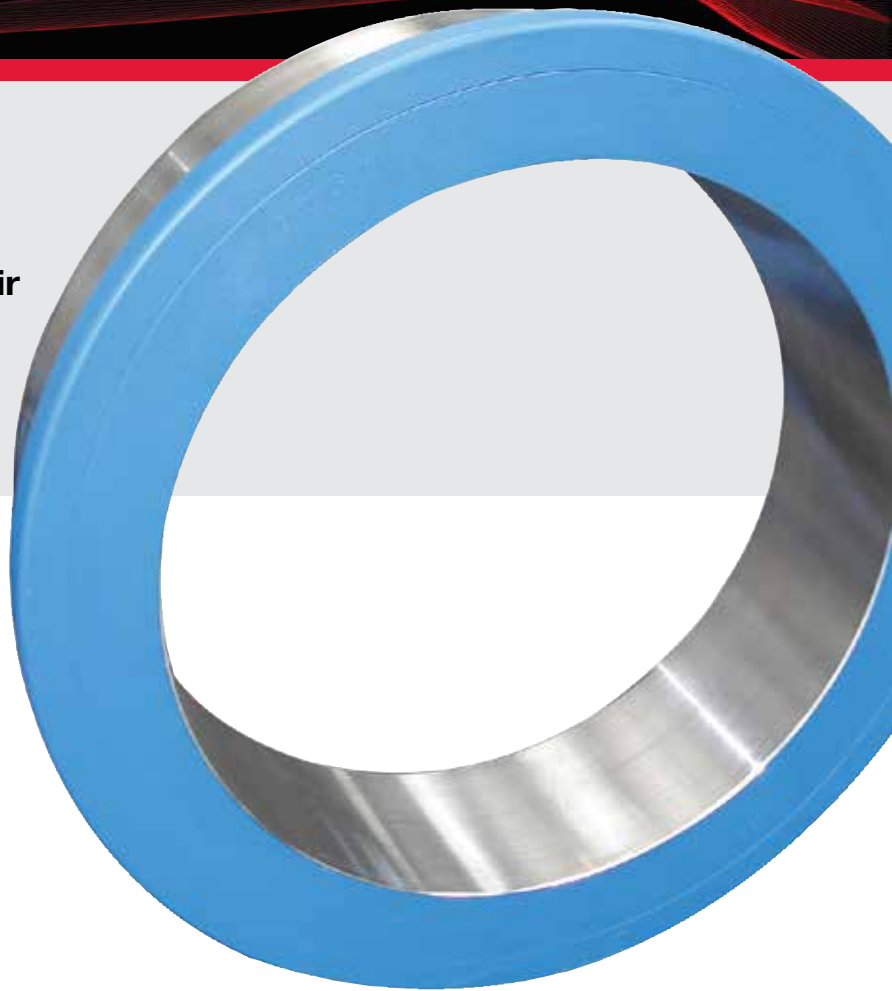

Improving Performance in a Variety of Systems:

- Overhead cranes & industrial rail
- Kilns, barge unloading systems and stadium roofs
- Mining & rotational radar surveillance systems
- Cab rollers, trunnion rollers, tyres and guide rollers



Guide rollers



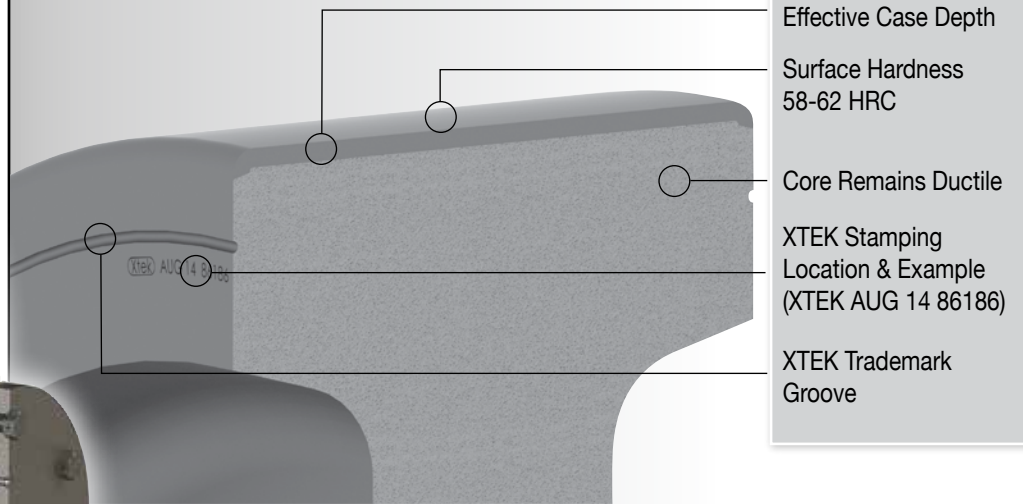
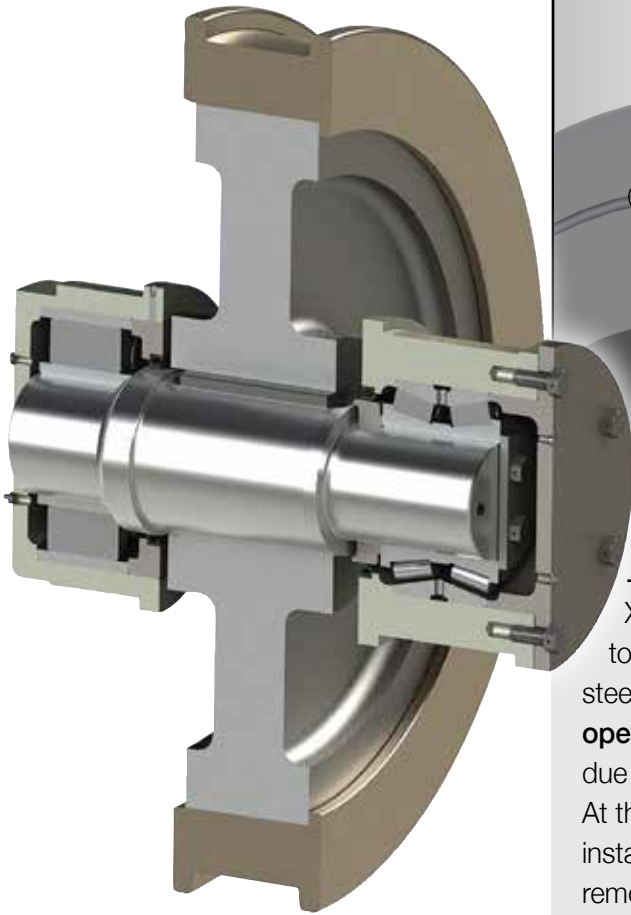

Effective Case Depth
 Surface Hardness
 58-62 HRC
 Core Remains Ductile
 XTEK Stamping
 Location & Example
 (XTEK AUG 14 86186)
 XTEK Trademark
 Groove

CASE STUDY

Xtek and a competitor were asked to provide two wheels for test within a steel mill processing crane. **Xtek wheels operated for 44 months** before removal due to mild wear on the tread and flange. At that time, the competitor's wheels were installed. The **competitor's wheels** were removed after **only 3 months of service** due to excessive wear.



Xtek wheels carry the stress so you don't have to!

Xtek = 40% Increase in Load Capacity

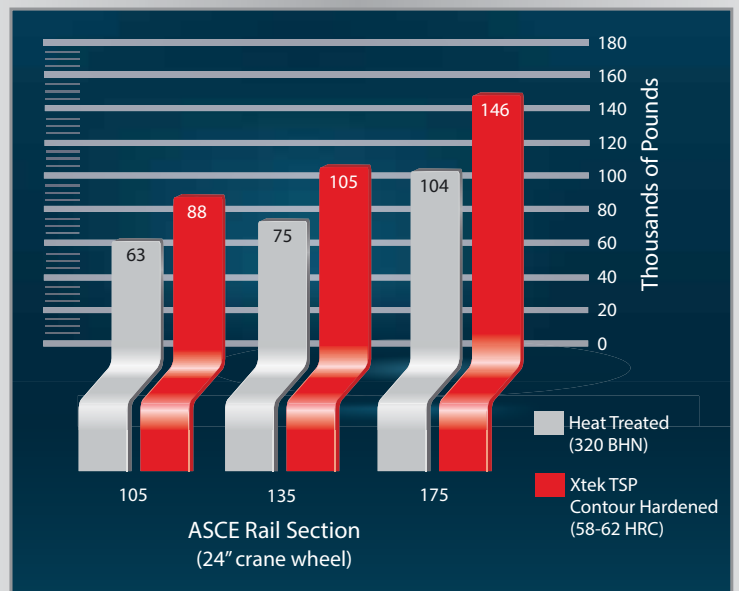

V-groove rollers for coil car application

Sheave Wheels

Xtek's TSP sheave wheels are designed and manufactured to safely lift the heaviest, most demanding loads.

Xtek TSP Sheave Wheels Improve Life of Cable Carrying Systems

Xtek's proprietary, consistent surface contour hardening process results in:

- Surface hardness range up to 62 HRc, significantly higher than hardness of wire rope
- No strand impressions, throat diameter polishes over time reducing friction
- Increases wire rope life by as much as 5 times
- High surface strength allows increased load capability
- Extends the duration between replacement
- Reduces time and costs associated with replacements
- Increases safety and productivity



Other heat-treatments produce inconsistent hardness profiles, which will lead to premature wear.

Competitors
Worn Sheave
after 6 months
of service

Xtek Sheave
after 3 years
of service



The weakness of competitors soft sheaves wheels:

Wear in the throat reduces wheel and wire rope life.

Wear Causes:

- **Crushing:** Compressive Forces Under Heavy Loads
- **Imprinting:** Wire Rope Twisting = Strand Impressions = Pinched/ Fractured/Cut Wire Rope Strands
- **Abrasive Wear**



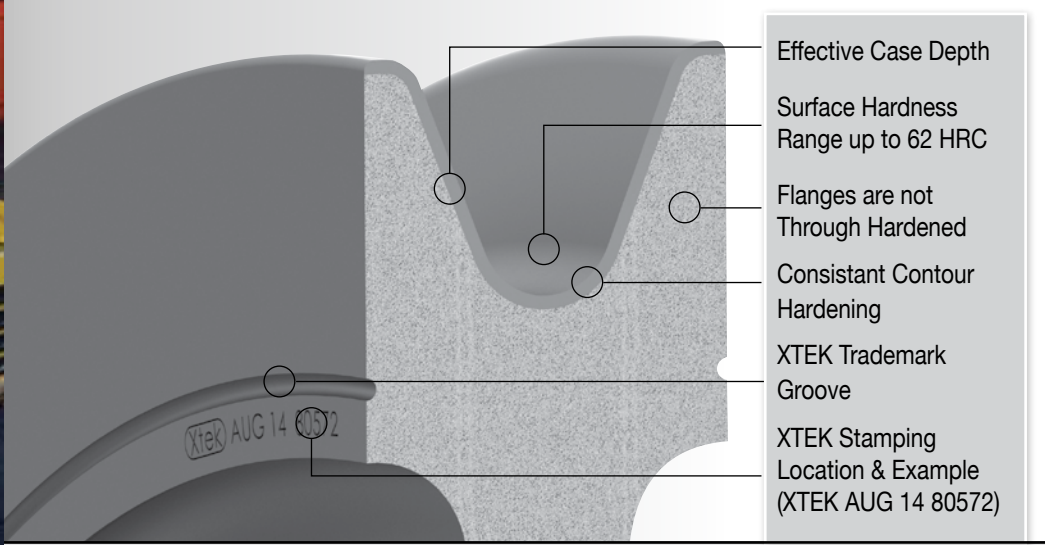

Xtek's TSP Sheave Wheels Perform Safely in the Toughest Environments

- Ladle cranes
- Steel scrap cranes
- Cranes with side pull requirements
- Shipyard & port cranes
- Mining drag lines & shovels
- Petrochemical
- Cable cars

THE CASE FOR XTEK TSP SHEAVE WHEELS

Application	Coke operation
Equipment	2 Overhead cranes and conveyor system
Original Sheave Wheel	Flame Hardened (50 HRc)
Problem	<ul style="list-style-type: none"> • Excessive sheave and rope wear • Heavily abrasive environment • Sheaves were replaced every 6 months • Wire rope were replaced every 6 weeks
Xtek Solution & Results	Implement Xtek TSP sheave wheel (60 HRc)
Xtek Sheave Wheel	Minimal wear after 3 years
Wire Rope	Increased service from 6 weeks to 18 weeks. Significant reduction in downtime
3 Year Cost Savings	Over 5 sheave replacements and 17 changes of rope were avoided. Equating to \$149,000 of savings in 3 years and the Xtek TSP sheaves wheels remained in service.

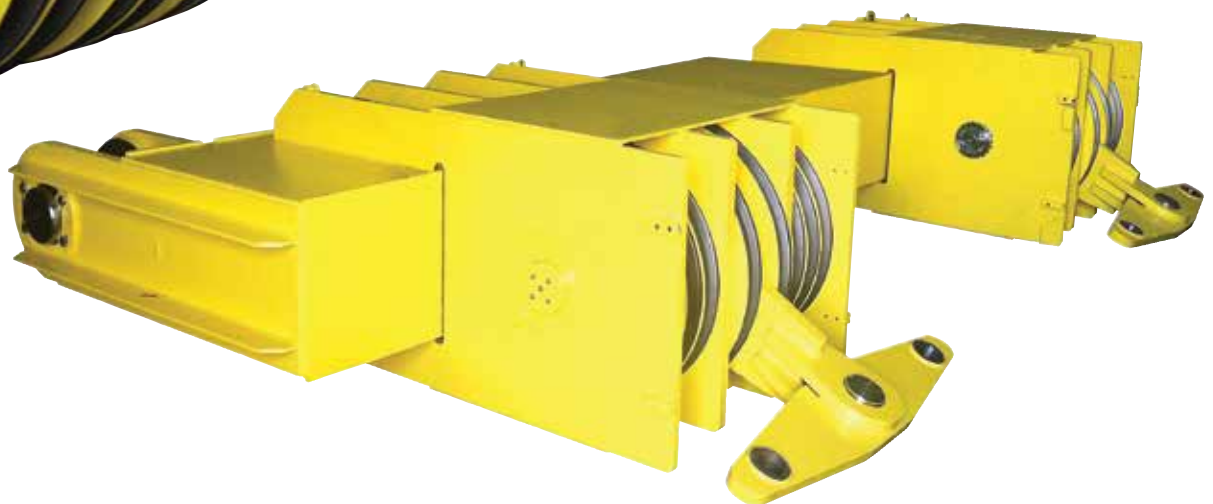

Brake Wheels

Xtek's Steel Safe™ brake wheels are designed mechanically and metallurgically to provide safe operation in the most hostile environments.

Xtek Steel Safe™ Brake Wheels Offer a Superior Combination

- Brake wheels are forged from steel, never from failure prone cast iron
- Exclusive Xtek metallurgical and heat-treatment processes
- Dynamically balanced through machining, never welded on weights

Xtek has the Solution - Forged Steel and Heat Treatment

- Significant increase in tensile strength compared to cast iron
- Unsurpassed resistance to frictional wear and thermal cracking
- Excellent abrasive wear characteristics, high fracture toughness
- Dissipates heat with minimized vibrations

The Result - Greater Operator Confidence

Longer, more reliable product life along with safer operating conditions, which equates to improved operating efficiencies and increased value.



Safely Lifting and Holding Applications Such as:

- Overhead cranes
- Port cranes
- Rotating machinery
- Tilt drives

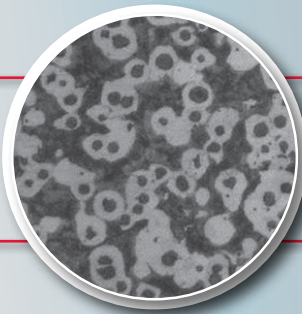

Microphotograph showing the open, crack prone structure of ordinary cast iron brake wheels.

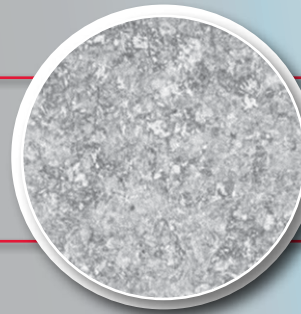

The microstructure of Xtek forged steel brake wheels exhibits a dense martensitic matrix, which inhibits cracking.



Brake wheel entering and exiting heat treating furnace.

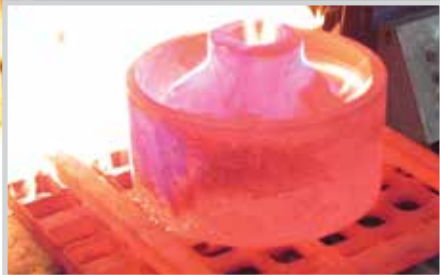

Brake wheel during turn complete operation.

Product Spotlight



Xtek's Steel Safe™ brake wheels hold the tilt operation of a 200 Ton ladle of molten steel: Our brake wheels outlast the typical campaign length of the mechanical system, allowing maintenance personnel to focus attention elsewhere.

Xtek wheels are dynamically balanced to ensure reliable, vibration free performance



Xtek Steel Safe™ brake wheel versus cast iron:

- 32x increase in Charpy V-Notch impact strength
- 1.3x increase in strength
- 16%-32% increase in wear resistance
- 3x increase in thermal fatigue

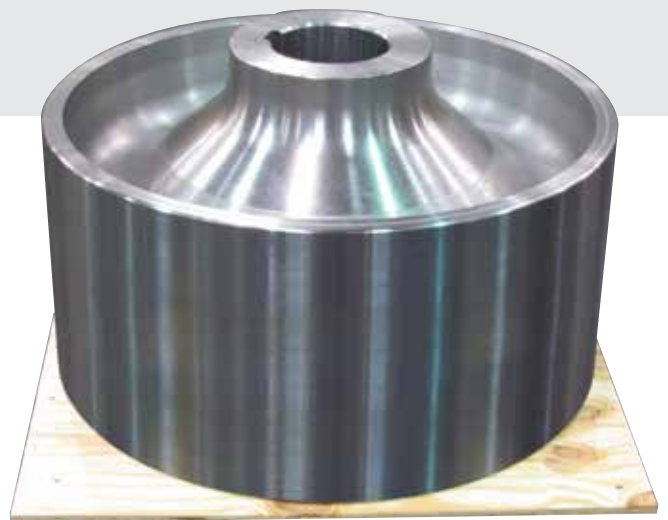

Xtek is Dedicated to Service and Beyond.



Regional Service and Reconditioning Facilities

- Staffed with mechanical and metallurgical engineers
- Focused on rebuilding worn and inferior assemblies
- 24/7 rush, emergency and breakdown support

Mechanical System Experts

- Manufacturer of complimentary parts
- Gearing and gearboxes
- Sheave nest assemblies
- Below hook lifting equipment

Leveraging the Latest Technology

- Finite Element Analysis (FEA)
- Portable 3-D scanner
- Coordinate Measuring Machines (CMM)

Comprehensive Results

- Every part is mechanical and nondestructive tested as required
- Comprehensive, itemized inspection reports

Realized Benefits

- Superior components & assemblies
- Designed for safety
- Built to last
- Reducing operating costs

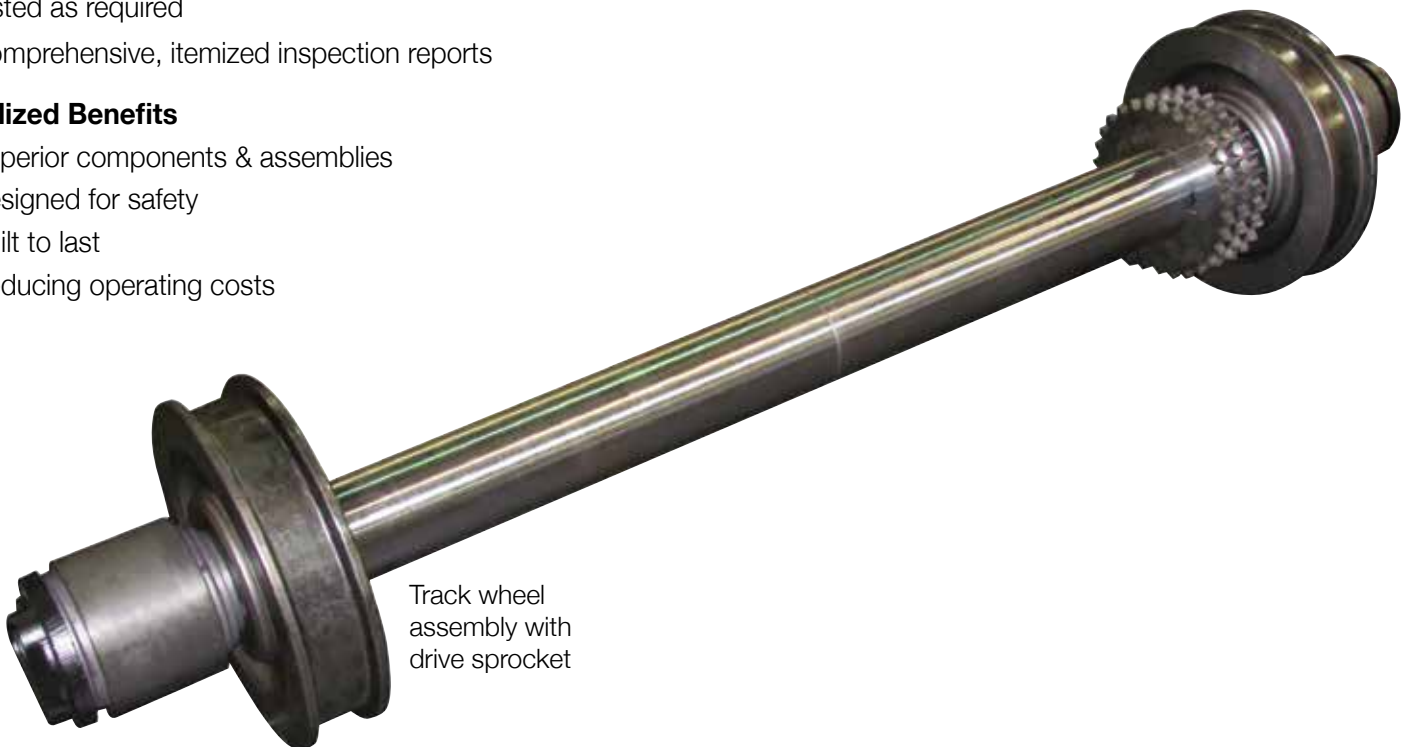
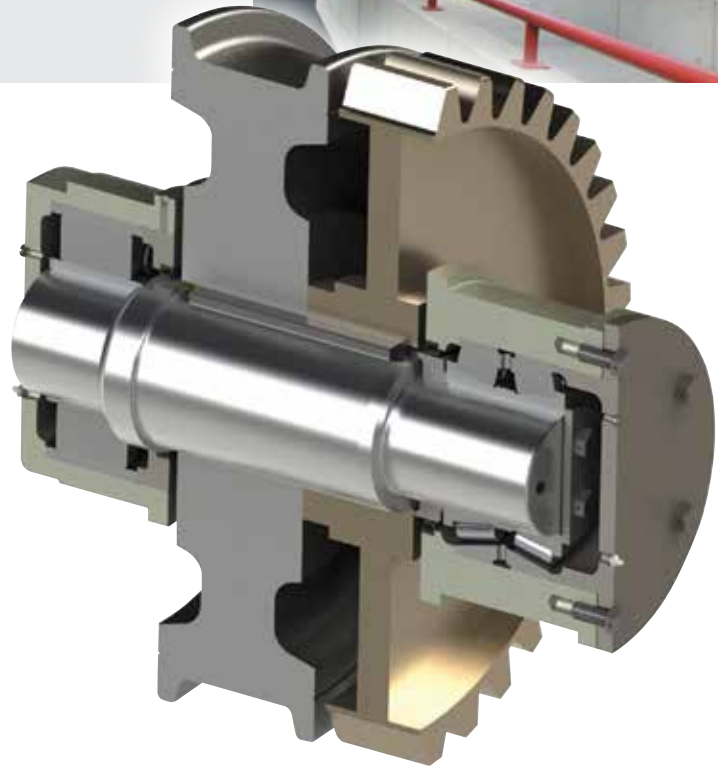

Track wheel
assembly with
drive sprocket

Stocked and Ready

Raw material inventory managed to respond quickly to wide variety of product mix needs.



Improvement in Design and Reliability



Customer sample



Xtek upgrade in design, material and heat treatment



Quickly responding to customers' needs

No Prints? No Problem!



3D laser scanner

- Verifies dimensions on finished parts
- Generates solid models of complex parts
- Provides high precision and accuracy required in engineering analysis



End truck assembly



A Trusted
World Leader
in Heavy Industry
Components for
Over 100 Years.

Gearing and Gearboxes



- AGMA 15 capability
- TSP carburizing to 58-62 HRc
- Gear diameters from 10" - 100"
- Up to 100,000 pounds
- Reverse engineering and FEA analysis
- Gearbox reconditioning specialists



Universal Joints

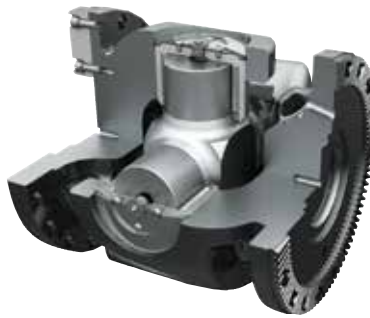

- Xtek manufactures closed-eye, split-eye, and block-type tight joints
- 220mm – 800mm standard sizes, others available upon request and evaluation
- A variety of flange connections are offered including: face key, integral pad, welded, and hirth serrations
- Special customized design features will be evaluated based upon the application



Gear Spindle Couplings



- World leader in couplings
- All driveshaft products are custom designed for your application
- All wear components TSP carburized to 58-62 HRc
- Reconditioning specialists





Rope Drums

Below-the-Hook Lifting Products

Bemcalloy™ Pinch Rolls



- Design and manufacturing of rope drums, TSP carburized and hardened to 60 HRC minimum
- TSP rope drums increase the life of rope by reducing coefficient of friction between drum and rope
- Xtek is capable of a variety of rope drum heat treatments, based on the application requirements
- Xtek provides numerous rope drum reconditioning services

- Design & manufacturing of heavy duty lifting equipment
- Multiple options for handling coil, slab, sheet, ingot, tube and specialty products
- Licensed, professional engineers on staff
- Lifter inspection services
- Repair and retrofitting of all lifter brands

- Design and manufacturing of pinch rolls that catch the strip and direct it down into the coiler
- Excellent wear and material pick-up resistance
- High strength and resistant to thermal fatigue/thermal shock
- Highly qualified provider of customized pinch roll reconditioning services

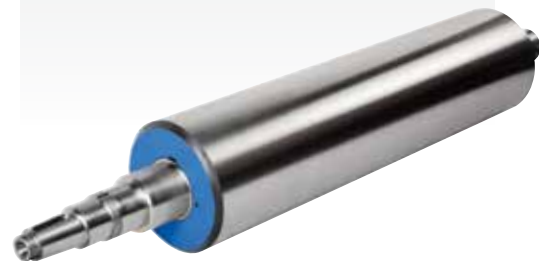
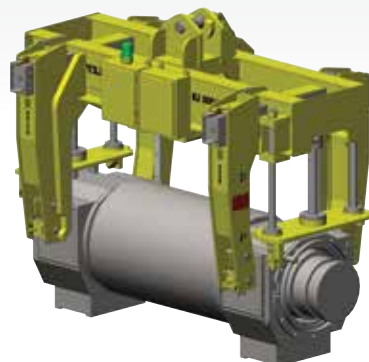



Global Headquarters

11451 Reading Road
Cincinnati, OH 45241
513.733.7800
1.888.332.9835
513.733.7894 fax

Xtek is employee owned and driven to serve our customers' needs.

For more details please contact your Xtek sales representative.

You can also reach us by phone at **513.733.7800**, email (sales@xtek.com), or xtek.com for further information. You can also find us on these social platforms:



Solutions in MotionSM

The XTEK Family of Companies



Hamilton, Ontario, Canada



AN Xtek COMPANY

York, PA 17403



Menomonee Falls, WI 53051



Plzen, Czech Republic



Paducah, KY 42002