

Xtek[®]

Solutions In Motion[™]



Xtek, Inc.
11451 Reading Road
Cincinnati, Ohio 45241
Telephone: (513) 733-7800 Fax: (513) 733-7969
Toll Free Number: (888) 332-9835 (XTEK)
24-Hour Hotline: (513) 733-7984
www.xtek.com



Xtek

*Crane
Products & Services*





• • • • • • • • • • ***A Different Kind of Company***

Xtek is a company built on experience, ingenuity and effort. Over the years, Xtek has thrived by working shoulder to shoulder with customers in the world's rolling mills; mines; ports and shipyards; pulp and paper mills; logging operations; and other industries where applications are severe and environments harsh.

Xtek grew strong by solving industry's toughest wear and breakdown problems with products that were both technologically and mechanically superior to the capabilities of the products they replaced. And that heritage lives in the Xtek of today. *Xtek continues to excel because it helps customers manage the maintenance portion of the value chain.*

Today's Xtek is a natural extension of the metallurgical and engineering firm founded almost a century ago. It's an employee owned company of dedicated problem solvers, just as it was in 1909. A technology company. A company of application engineers, designers, metallurgists, service technicians, skilled machinists and innovative heat treaters. At Xtek, technology, craftsmanship and people converge to produce unmatched customer service. And that is what makes Xtek a different kind of company.

• • • • • • • • • • • • • • • • ***At Xtek, We Don't Make Cranes,
We Make Cranes Better.***

Xtek's reputation for long wearing, reliable crane components was earned in one of industry's most brutal and demanding environments - that of the integrated steel mills, where Xtek quickly learned that ordinary products just weren't good enough.

By applying a new, proprietary carburizing technology, the Tool Steel Process (TSP), Xtek was able to dramatically improve the durability and performance of those crane components that require increased wear resistance and increased load carrying capability. Other technologies followed, so that today, Xtek can offer a complete package of safe, low maintenance crane components. Track wheels that defy wear and make rails last longer. Rope drums that usually outlive the crane. Sheave wheels lasting almost as long, while extending wire rope life 300-600%. Gearing capable of 30-50% more torque. Superior brake wheels that resist fracturing and catastrophic failure.

In rolling mills, ports, shipyards, logging and many other heavy-duty applications where failure is not an option, Xtek has become the recognized brand of choice. Tough. Strong. Practical. Xtek crane components make cranes better.

Advanced Metallurgy



Track Wheels

- Xtek track wheels are *contour case hardened* to 58-62 Rockwell C for extended tread and flange life.
- The differentially hardened zones in Xtek track wheels provide valuable shock absorption qualities that protect flanges against impact breakage.
- High grade forged steel and proprietary Xtek metallurgy produce track wheels with 40% more load carrying capacity to defeat the effects of pitting and spalling.



Replacement Gearing

- Exclusive TSP carburized and ground tooth gearing provides unsurpassed load carrying capability.
- A deep, uniform 58-62 Rockwell C hardened case across the entire profile and root results in unrivaled wear resistance.
- With a core hardness of 28-32 Rockwell C, Xtek TSP gearing readily absorbs operating shocks and extends service life.

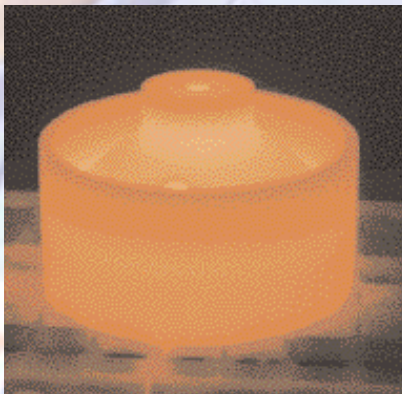

SteelSafe™ Brake Wheels

- Made of vacuum degassed forged steel, SteelSafe wheels are free of the voids and impurities that initiate fatigue, cracking and catastrophic failure in cast iron wheels.
- Xtek's proprietary SteelSafe process vastly refines brake wheel microstructure, improving mechanical strength in the rim, web and hub.
- Heat treatment is adjusted for in-service conditions to create the ideal combination of wear resistance and impact toughness to assure a long useful life.



TSP Rope Drums & Sheave Wheels

- Crushing and corrugation of rope drum and sheave wheel grooves is virtually eliminated by TSP metallurgy. (Compare the Xtek wheel, at left, to the severely corrugated competitor's wheel at right.)
- The deep, hardened case in the groove actually becomes polished with use, decreasing friction and prolonging product life.
- Xtek sheave wheels and rope drums are made from high quality, low carbon steel, carburized and hardened to provide longer life and higher reliability than cast iron products.

How Xtek Makes

Track Wheels & Assemblies

In mills and plants around the world, Xtek track wheels and assemblies are the acknowledged standard for long life, reliability and value. Flanges that defy failure, reduced downtime and extended wear are the result of tightly controlled, application-specific heat treating technologies found only at Xtek. Production proven in the most demanding environments, *engineered* Xtek track wheels are your best choice where high speeds, longer travel distances and high loads are factors. Every day, in hundreds of applications, dependable Xtek track wheels are rewarding their owners with the measurable cost savings of long life and low maintenance.

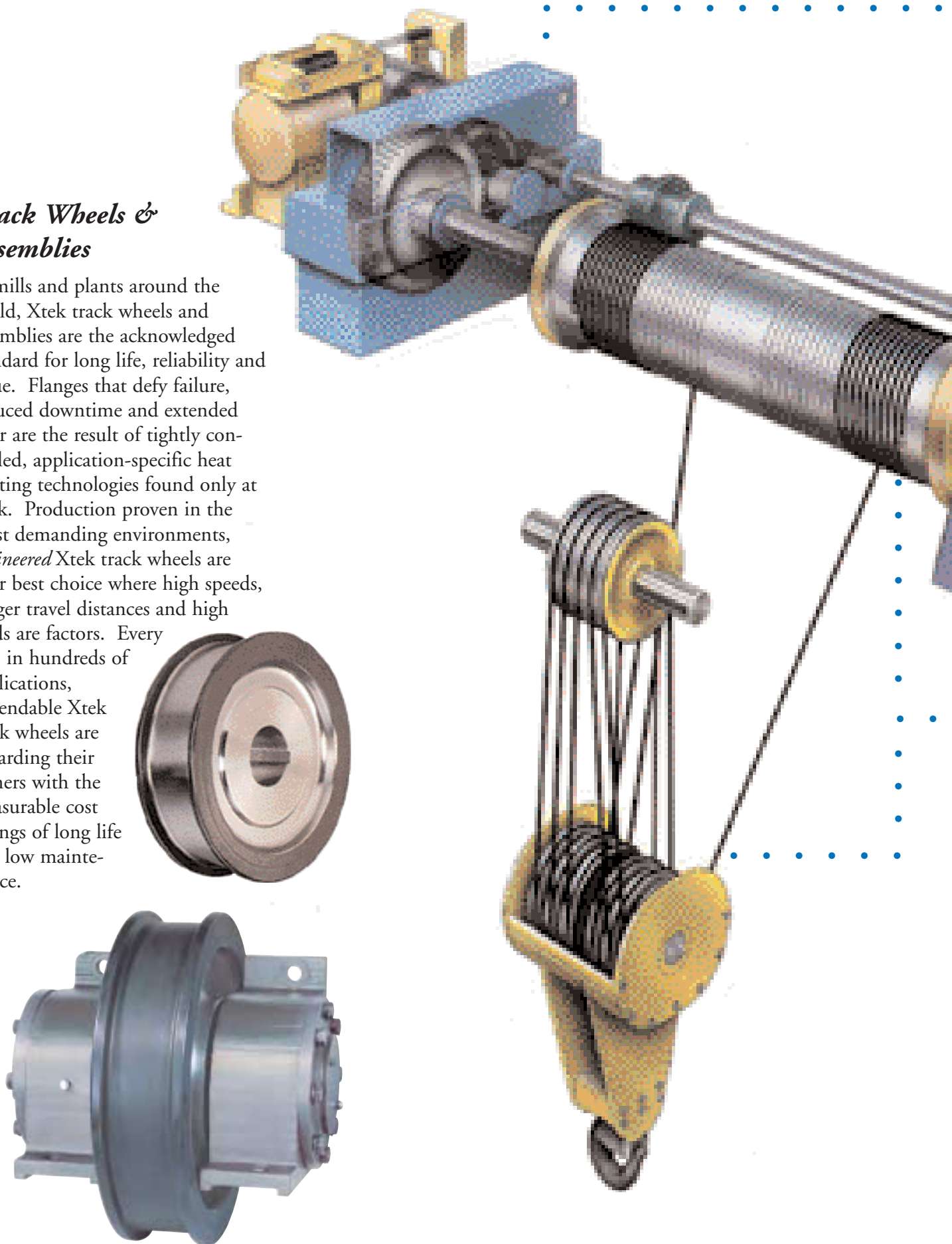

a Crane Better

• *Crane Gearing*

One of America's most experienced, and most respected manufacturers of gearing for power transmission, Xtek has long been a worldwide leader in gear technology. Xtek's proprietary TSP metallurgy produces gearing capable of handling 30-50% more torque than through hardened gearing of the same size. That means load carrying capacity can be increased without modifying your existing gearbox. It means extended gear life. It means reduced maintenance costs. It means that anytime you're considering a gearing upgrade; Xtek should be your first call.

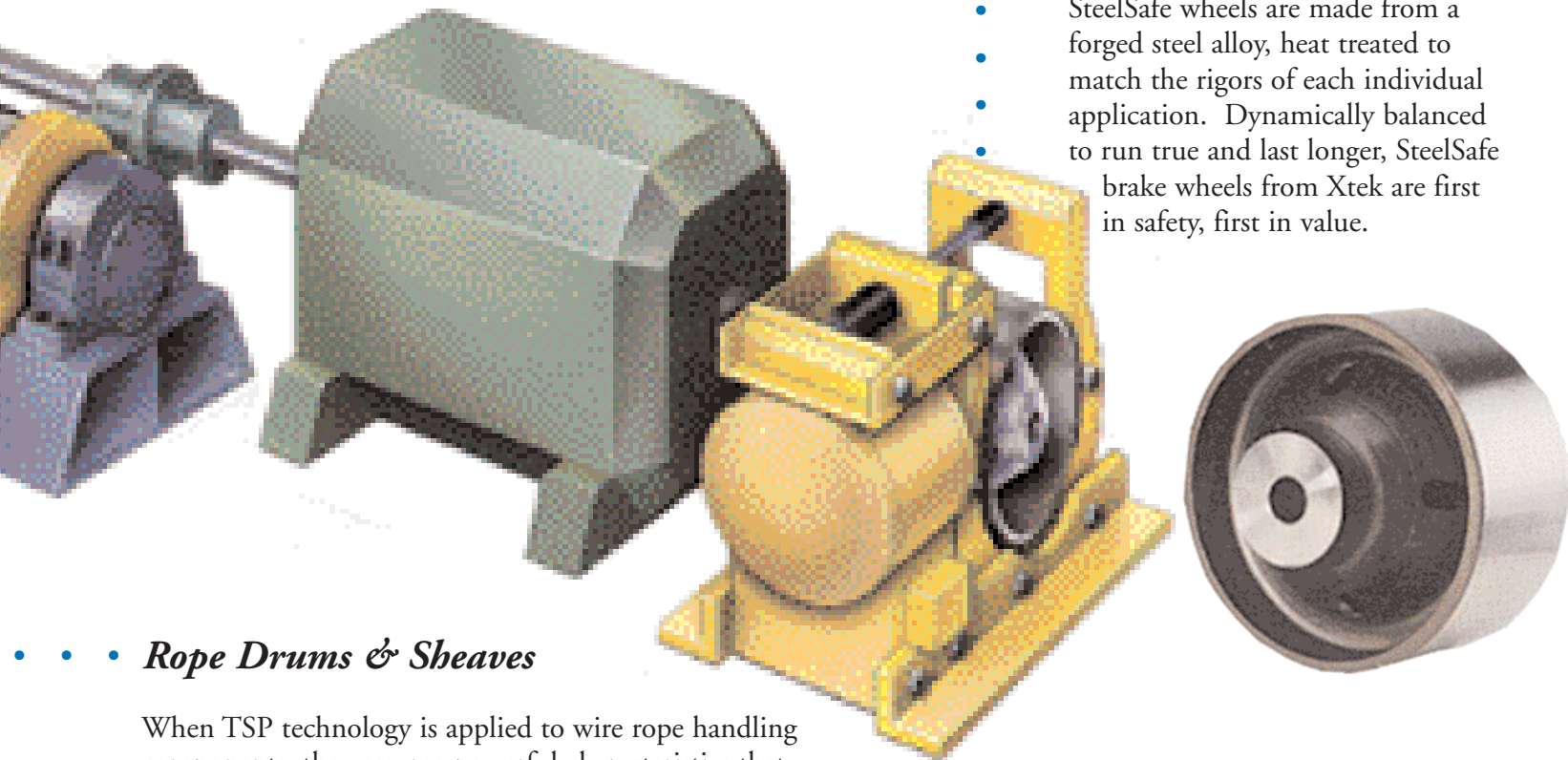

• • *SteelSafe Brake Wheels*

Xtek brake wheels are at least 50% tougher, safer and less prone to catastrophic failure than any cast iron wheel. They are tougher and better able to resist both crack propagation and stress fatigue because SteelSafe wheels are made from a forged steel alloy, heat treated to match the rigors of each individual application. Dynamically balanced to run true and last longer, SteelSafe brake wheels from Xtek are first in safety, first in value.

• • • *Rope Drums & Sheaves*

When TSP technology is applied to wire rope handling components, they assume powerful characteristics that counter the destructive forces of rope strand imprinting and side-pulling that cause premature wear. Remarkably, case hardened Xtek sheave wheels and rope drums not only last more than five times longer than competitive products, but it's well documented that they also extend the life of wire rope 300-600%. Frequently recommended by manufacturers of wire rope, no one is more effective than Xtek in reducing the overall maintenance costs of crane components.



With a heritage of almost one hundred years of overhead crane application experience, Xtek:

- Knows the value of analyzing a customer's application before recommending a specific solution
- Is focused on helping reduce your crane maintenance costs
- Is ready to solve your emergency needs
- Is active in writing industry crane design standards as part of the "AIST No.6 Subcommittee for Electrical Overhead Traveling Cranes"
- Is a member of AGMA (American Gear Manufacturer's Association)—Enclosed Drive Gearing Committee
- Is ISO: 9001:2000 certified

